

Part number key

Modular	#####
Standard	#####
Special	#####

¹ Other ratios available on request (1): 6, 8, 9, 12, 13, 14, 18, 25, 33, 44, 54, 66

Technical data

1 Part number		M4B	M5B	M10B	M16B	M20B	M30B	M40B	M48B	M60B	M72B
2 Gear ratio ¹	:1	4	5	10	16	20	30	40	48	60	72
3 Stages		1	1	11	1	1	1	1	1	1	1
4 Max. continuous torque (S1)	Nm	12.0	12.0	12.0	12.0	12.0	12.0	12.0	12.0	9.0	8.0
5 Max. intermittent torque (S2 - 15 minutes) ²	Nm	19.0	19.0	19.0	19.0	19.0	19.0	19.0	19.0	14.0	12.0
6 Efficiency	%	74	74	71	67	64	61	57	50	47	40
7 Backlash	arc.min	10-25	10-25	10-25	10-25	10-25	10-25	10-25	10-25	10-25	10-25
8 Max. axial load (dynamic)	N	300	300	300	300	300	300	300	300	300	300
9 Max. radial load, 12 mm from flange	N	350	350	350	350	350	350	350	350	350	350
10 Weight	kg	0.9	0.9	0.9	0.9	0.9	0.9	0.9	0.9	0.9	0.9
11 Gear material		Bronze	Bronze	Bronze	Bronze	Bronze	Bronze	Bronze	Bronze	Bronze	Bronze

² S1 & S2 duty cycles based on 3000 RPM input speed

Modular system

BLDC motor	+L mm	AC motor	+L mm	AC motor	+L mm
PBL60-50	90	SD8	125	SD28	144
PBL60-70	110	SD13	152	SD29	147
		SD18	158	SD38	128
		SD21	95	SD41	107

+L mm = added length



PMDC motor	+L mm	PMDC motor	+L mm
PM1	149	PM6	175
PM2	162	PM10	107
PM3	137	PM11	126
PM4	149	PM50	180
PM5	162	PM60	193

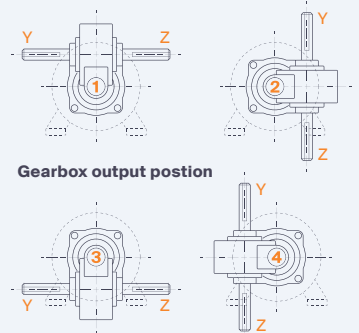

Gearbox output position